



4511

Communication enabler

No. 4511V100-UK

From ser. no 131452001



- DK** ▶ PR electronics A/S tilbyder et bredt program af analoge og digitale signalbehandlingsmoduler til industriel automation. Programmet består af Isolatorer, Displays, Ex-barrierer, Temperaturtransmittere, Universaltransmittere mfl. Vi har modulerne, du kan stole på i selv barske miljøer med elektrisk støj, vibrationer og temperaturudsving, og alle produkter opfylder de strengeste internationale standarder. Vores motto »Signals the Best« er indbegrebet af denne filosofi - og din garanti for kvalitet.
- UK** ▶ PR electronics A/S offers a wide range of analogue and digital signal conditioning devices for industrial automation. The product range includes Isolators, Displays, I.S. Interfaces, Temperature Transmitters, and Universal Devices. You can trust our products in the most extreme environments with electrical noise, vibrations and temperature fluctuations, and all products comply with the most exacting international standards. »Signals the Best« is the epitome of our philosophy - and your guarantee for quality.
- FR** ▶ PR electronics A/S offre une large gamme de produits pour le traitement des signaux analogiques et numériques dans tous les domaines industriels. La gamme de produits s'étend des transmetteurs de température aux afficheurs, des isolateurs aux interfaces SI, jusqu'aux modules universels. Vous pouvez compter sur nos produits même dans les conditions d'utilisation sévères, p.ex. bruit électrique, vibrations et fluctuations de température. Tous nos produits sont conformes aux normes internationales les plus strictes. Notre devise »SIGNALS the BEST« c'est notre ligne de conduite - et pour vous l'assurance de la meilleure qualité.
- DE** ▶ PR electronics A/S verfügt über ein breites Produktprogramm an analogen und digitalen Signalverarbeitungsmodulen für die industrielle Automatisierung. Dieses Programm umfasst Displays, Temperaturtransmitter, Ex- und galvanische Signaltrenner, und Universalgeräte. Sie können unsere Geräte auch unter extremen Einsatzbedingungen wie elektrisches Rauschen, Erschütterungen und Temperaturschwingungen vertrauen, und alle Produkte von PR electronics werden in Übereinstimmung mit den strengsten internationalen Normen produziert. »Signals the Best« ist Ihre Garantie für Qualität!

COMMUNICATION ENABLER 4511

CONTENTS

Warning.....	2
Safety instructions.....	3
Applications.....	5
Technical characteristics.....	5
Mounting / installation / programming.....	6
Mounting.....	7
Order codes	8
Specifications	8
4511 installation examples	10
Modbus basics.....	11
4511 Modbus parameter settings.....	12
4511 Modbus settings - routing diagram.....	13



GENERAL



**HAZARD-
OUS
VOLTAGE**



CAUTION

WARNING

This device is designed for connection to hazardous electric voltages. Ignoring this warning can result in severe personal injury or mechanical damage.

To avoid the risk of electric shock and fire, the safety instructions of this guide must be observed and the guidelines followed. The specifications must not be exceeded, and the device must only be applied as described in the following.

Prior to the commissioning of the device, this installation guide must be examined carefully.

Only qualified personnel (technicians) should install this device. If the equipment is used in a manner not specified by the manufacturer, the protection provided by the equipment may be impaired.

WARNING

Until the device is fixed, do not connect hazardous voltages to the device. The following operations should only be carried out on a disconnected device and under ESD safe conditions:

General mounting, connection and disconnection of Modbus cable.
Troubleshooting the device.

WARNING

Repair of the device must be done by PR electronics A/S only.

SYMBOL IDENTIFICATION



Triangle with an exclamation mark: Read the manual before installation and commissioning of the device in order to avoid incidents that could lead to personal injury or mechanical damage.



The **CE mark** proves the compliance of the device with the essential requirements of the directives.



The **double insulation** symbol shows that the device is protected by double or reinforced insulation.



Ex devices have been approved according to the ATEX directive for use in connection with installations in explosive areas.

SAFETY INSTRUCTIONS

RECEIPT AND UNPACKING

Unpack the device without damaging it. The packing should always follow the device until this has been permanently mounted. Check at the receipt of the device whether the type corresponds to the one ordered.

ENVIRONMENT

The device is manufactured for indoor use. Avoid direct sunlight, dust, high temperatures, mechanical vibrations and shock, as well as rain and heavy moisture. If necessary, heating in excess of the stated limits for ambient temperatures should be avoided by way of ventilation.

The device may be used in Overvoltage Category II, Pollution Degree 2 at an altitude up to 2000 m.

MOUNTING

Only qualified technicians who are familiar with the technical terms, warnings, and instructions in this installation guide and who are able to follow these should connect the device. Only devices which are undamaged and free of moist and dust may be installed. The device may be installed and supplied by PR electronics 4000 and 9000 series only. Should there be any doubt as to the correct handling of the device, please contact your local distributor or, alternatively, PR electronics A/S.

CALIBRATION AND ADJUSTMENT

During calibration and adjustment, the measuring and connection of external voltages must be carried out according to the specifications of this installation guide. The technician must use tools and instruments that are safe to use.

CLEANING

When disconnected, the device may be cleaned with a cloth moistened with distilled water.

IECEX, ATEX INSTALLATION IN ZONE 2

IECEX DEK 13.0026 X..... Ex nA IIC T5 Gc

DEKRA 13ATEX0098 X..... II 3 G Ex nA IIC T5 Gc

FOR SAFE INSTALLATION THE FOLLOWING MUST BE OBSERVED

The device must be installed by qualified personnel who are familiar with the national and international laws, directives and standards that apply to this area. Year of manufacture can be taken from the first two digits in the serial number.

The devices must be installed in a suitable enclosure providing a degree of protection of at least IP54 according to EN60529, taking into account the environmental conditions under which the equipment will be used.

To prevent ignition of the explosive atmospheres do not separate connectors when energized and an explosive gas mixture is present.

To avoid the risk of explosion due to electrostatic charging of the enclosure, do not handle the units unless the area is known to be safe, or appropriate safety measures are taken to avoid electrostatic discharge.

COMMUNICATION ENABLER 4511

- *Programming display for system 4000 and 9000 devices*
- *Modbus RTU protocol interface over RS-485*
- *Monitor process value from the built-in display*
- *High 2.5 kV isolation to host unit*
- *Shielded RJ45 Modbus connector on top*

Applications

- The 4511 detachable display adds Modbus RTU RS-485 serial communications to all current and future 4000/9000 units.
- The unit converts a wide array of sensors and analog device signals measured by the system 4000, like uni- and bipolar mA and voltage signals, potentiometer, Lin. R, RTD and TC, to a Modbus communication line signal.
- When mounted on a system 9000 device any signal coming from or going to I.S. classified area, like AI, AO, DI and DO signals, can be converted to a Modbus network.
- All individual unit operating parameters can easily and quickly be configured by using the Modbus communication or by using the front display menu.
- The easily readable 4511 display can be used to read the process signal, simulate the output signal, indicate sensor errors and internal module errors.

Technical characteristics

- 4511 has full 4501 functionality for unit programming, process signal monitoring and diagnostics handling.
- Modbus RTU protocol is supported using a serial RS-485 communication wiring.
- Multidrop half-duplex connection via shielded RJ45 connector.
- High safe galvanic isolation of 2.5 kVAC between the serial wiring and the connected system 4000/9000 units.
- Modbus parameters such as address, baud rate, stop bit(s), and parity bit are configured from the 4511 display, which also stores parameters.

Mounting / installation / programming

- Mounting in Zone 2 / Div 2.
- The 4511 can be moved from one device to another. The individual system 4000/9000 unit configuration of the first transmitter can be saved and downloaded to subsequent transmitters.
- Programmed parameters can be protected by a user-defined password.

MOUNTING

4511 is a detachable display that can be mounted on all system 4000/9000 fronts for programming and signal monitoring.

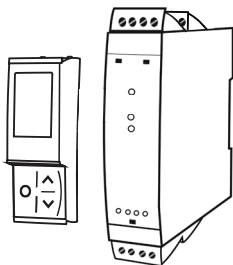

4511 contains a four line LCD dot display

Line 1 can e.g. show the scaled process value.
Line 2 can e.g. show the selected engineering unit.
Line 3 can e.g. show the analog output or TAG no.
Line 4 shows status for communication and e.g. signal trending.

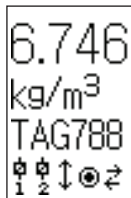

RJ45 Modbus Connector

Pin 5: RS485 A line
Pin 4: RS485 B line
Pin 8: RS485 GND and shield

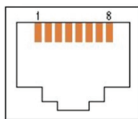

Order codes

4511 = Communication enabler

4590 = Configmate interface

4801 = Modbus gateway

Specifications

Environmental conditions:

Specifications range	-20°C to +60°C
Storage temperature	-20°C to +85°C
Relative humidity.....	< 95% RH (non-cond.)
Protection degree.....	IP20
Installation in pollution degree 2 / overvoltage category II.	

Mechanical specifications:

Dimensions (HxWxD).....	73.2 x 23.3 x 26.5 mm
Dimensions (HxWxD) w/ 4000/9000 unit....	109 x 23.5 x 131 mm
Weight approx.	100 g
Connection.....	RJ45 - shielded

Common electrical specifications:

Power consumption	≤ 0.15 W
Isolation voltage - test / working	2.5 kVAC / 250 VAC reinforced isolation

Extended EMC immunity: NAMUR NE 21, A criterion, burst	No loss of communication
---	--------------------------

Signal / noise ratio	> 60 dB
Update rate / response time	> 50 Hz / < 20 ms
Signal type	RS-485 half duplex
Serial protocol.....	Modbus RTU
Modbus mode.....	RTU - slave
Devices on an RS485 line.....	Up to 32 (without a repeater)
Data rates, baud	2400, 4800, 9600, 19200, 38400, 57600, 115200
Automatic baudrate detection	Yes - can be configured ON or OFF
Parity	Even, Odd, None
Stop bit(s).....	1 or 2
Digital addressing.....	1...247
Response delay	0...1000 ms

Approvals:

EMC 2004/108/EC	EN 61326-1
LVD 2006/95/EC.....	EN 61010-1
UL, Standard for Safety.....	UL 61010-1

Marine:

Det Norske Veritas, Ships & Offshore	Stand. f. Certific. No. 2.4
--	-----------------------------

Ex:

ATEX.....	DEKRA 13ATEX0098 X II 3 G Ex nA IIC T5 Gc
IECEX.....	DEK 13.0026 X Ex nA IIC T5 Gc
FM	0003049132-C CL I DIV2 GP A- D T5 CL I Zn2 Groups IIC T5 CL I Zn2 AEx/Ex nA IIC T5

4511 INSTALLATION EXAMPLES

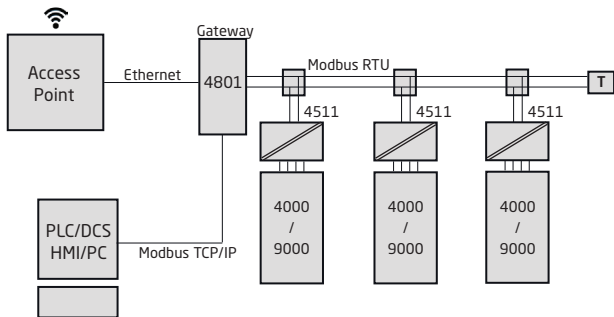
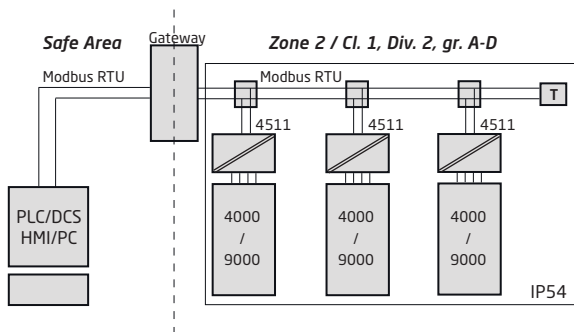
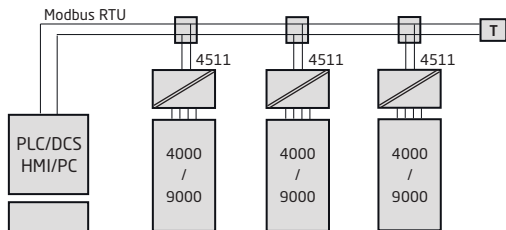

MODBUS BASICS

Modbus is a “master-slave” system...,

where the “master” communicates with one or multiple “slaves”.

The master typically is a PLC (Programmable Logic Controller), DCS (Distributed Control System), HMI (Human Machine Interface), RTU (Remote Terminal Unit) or PC.

The three most common Modbus versions used are: MODBUS ASCII, MODBUS RTU and MODBUS/TCP.

In Modbus RTU, data is coded in binary, and requires only one communication byte per data byte. This is ideal for use over multi-drop RS485 networks, at speeds up to 115,200 bps.

The most common speeds are 9,600 bps and 19,200 bps.

Modbus RTU is the most widely used industrial protocol and is supported by the 4511.

Modbus RTU:

To communicate with a slave device, the master sends a message containing:

Device Address - Function Code - Data - Error Check

The Device Address is a number from 0 to 247.

Messages sent to address 0 (broadcast messages) will be accepted by all slaves, but numbers 1-247 are addresses of specific devices.

With the exception of broadcast messages, a slave device always responds to a Modbus message so the master knows the message was received.

4511 Supported Modbus Function Codes:

Command	Function code
Read Holding Registers	03
Read Input Registers	04
Write Single Register	06
Diagnostics	08
Write Multiple Registers	16

The Function Code defines the command that the slave device is to execute, such as read data, accept data, report status. Some function codes have sub-function codes.

The Data defines addresses in the device's memory map for read functions, contains data values to be written into the device's memory, or contains other information needed to carry out the function requested.

The Error Check is a 16-bit numeric value representing the Cyclic Redundancy Check (CRC).

Maximum number of registers which can be read or written at once:

For a read command, the limit is 8 registers at a baud rate up to 38,400 bps, 16 registers @ 57,800 bps and 32 registers @ 115,200 bps.

For a write command, the limit is 123 registers at baud rates up to 115,200 bps.

4511 MODBUS PARAMETER SETTINGS

Automatic Baudrate Detection:

Can be configured YES or **NO**

Supported baudrates:

2400, 4800, 9600, **19.2k**, 38.4k, 57.6k, 115.2k bps

Parity Mode:

Even, Odd or None parity

Stop Bits:

1 or 2 stop bits

Response delay:

0...1000 ms (**0 ms = default**)

Modbus slave addressing range:

1 - 247 (**247 = default address**)

Modbus Parameter Storage:

Saved in non-volatile memory in the 4511 device

(Factory Default Values are marked in **bold**)

Modbus RTU segment line termination:

A 120 Ohm resistor should be installed on both ends of a RS485 Modbus RTU segment loop to prevent signal echoes from corrupting data on the line.

4511 MODBUS SETTINGS - ROUTING DIAGRAM

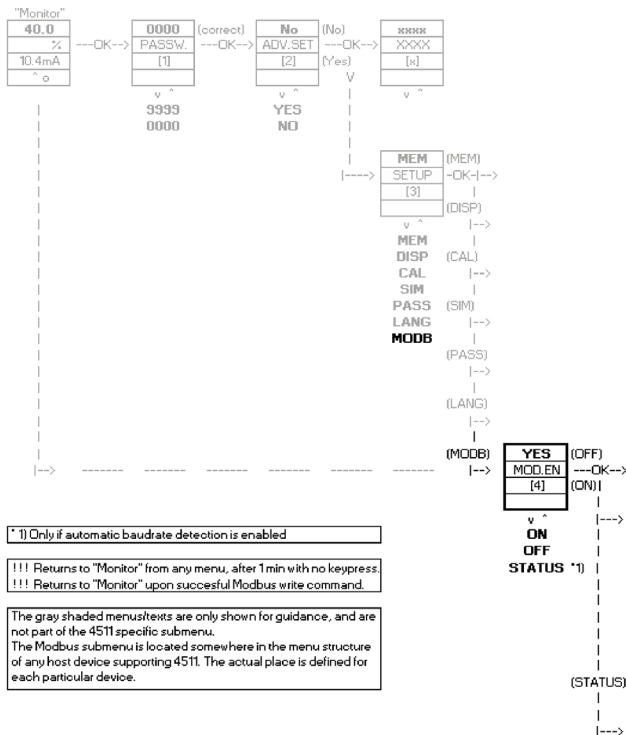

4511 MODBUS SETTINGS ROUTING DIAGRAM

SCROLLING HELPTXTS:

- [1] Set correct password
- [2] Enter advanced setup menu?
- [3] Enter Language setup
- Enter Password setup
- Enter Simulation mode
- Perform Process calibration
- Enter Display setup
- Perform Memory operations
- Enter Modbus setup
- [4] Enable modbus communication
- Disable Modbus communication
- See automatic baudrate detection status
- [5] Reset Modbus to default?
- [6] Select Modbus slave address
- [7] Select parity for Modbus
- [8] Select number of stop bits
- [9] Select response delay in ms
- [10] Enable automatic baudrate detection
- [11] Modbus baudrate not detected
- Searching for Modbus baudrate
- Modbus baudrate detected
- [12] Select baudrate in bps

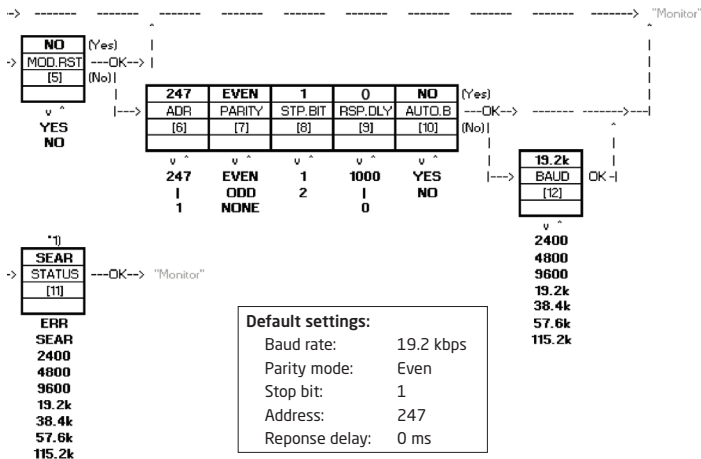



Displays Programmable displays with a wide selection of inputs and outputs for display of temperature, volume and weight, etc. Feature linearisation, scaling, and difference measurement functions for programming via PReset software.



Ex interfaces Interfaces for analogue and digital signals as well as HART® signals between sensors / I/P converters / frequency signals and control systems in Ex zone 0, 1 & 2 and for some devices in zone 20, 21 & 22.



Isolation Galvanic isolators for analogue and digital signals as well as HART® signals. A wide product range with both loop-powered and universal isolators featuring linearisation, inversion, and scaling of output signals.



Temperature A wide selection of transmitters for DIN form B mounting and DIN rail devices with analogue and digital bus communication ranging from application-specific to universal transmitters.



Universal PC or front programmable devices with universal options for input, output and supply. This range offers a number of advanced features such as process calibration, linearisation and auto-diagnosis.



  www.preelectronics.fr
 sales@preelectronics.fr

  www.preelectronics.de
 sales@preelectronics.de

  www.preelectronics.es
 sales@preelectronics.es

  www.preelectronics.it
 sales@preelectronics.it

  www.preelectronics.se
 sales@preelectronics.se

  www.preelectronics.com
 sales@preelectronics.com

  www.preelectronics.com
 sales@preelectronics.com

  www.preelectronics.cn
 sales@preelectronics.cn

Head office

Denmark
PR electronics A/S
Lerbakken 10
DK-8410 Rønde

www.preelectronics.com
sales-dk@preelectronics.com
tel. +45 86 37 26 77
fax +45 86 37 30 85



QUALITY SYSTEM AND ENVIRONMENTAL MANAGEMENT SYSTEM
DS/EN ISO 9001
DS/EN ISO 14001

